



## 應用

- 適用於家庭用水、設備加壓、管道增壓、花園、菜園澆水、養殖漁業、工業及礦業用水、企業和高樓建築的供水及中央空調和加熱循環系統等。

## 泵浦

- AISI 304軸心
- 最大流體溫度：+60°C
- 適用海拔高度：1000米以下
- 最大入口壓力：受最大操作壓力限制
- 最大操作壓力：10 Bar
- 流體PH值：6.5 - 8.5

## 馬達

- 馬達銅線線圈
- 單相馬達內建過熱保護開關
- 絕緣等級：F
- 保護等級：IP55
- 最高耐溫：+40°C

## 型號說明

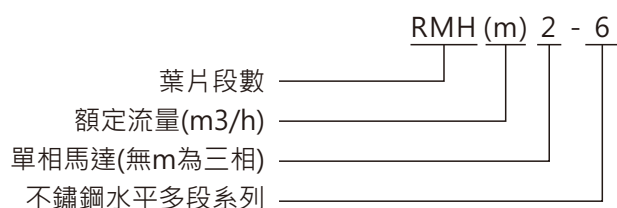

## 材質

No.	零件	材質
1	泵蓋	12鋁合金
2	泵體	不鏽鋼304
3	前段導葉輪	不鏽鋼304
4	葉輪	不鏽鋼304
5	中段導葉輪	不鏽鋼304
6	尾段導葉輪	不鏽鋼304
7	機械密封	碳化矽/碳
8	密封座	
9	支架	12鋁合金
10	前軸承	
11	轉子	
12	後軸承	
13	底板	Q235 碳鋼
14	定子	
15	後蓋	12鋁合金
16	風扇	聚丙烯
17	風扇罩	聚丙烯
18	接線盒	

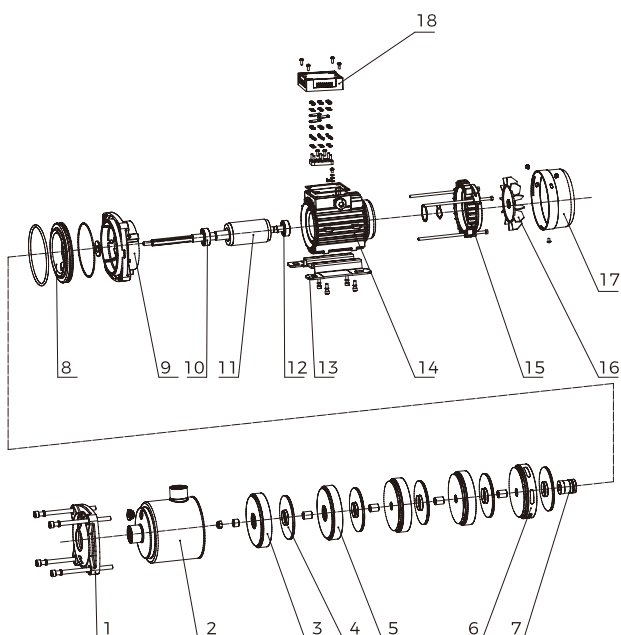

## 性能曲線

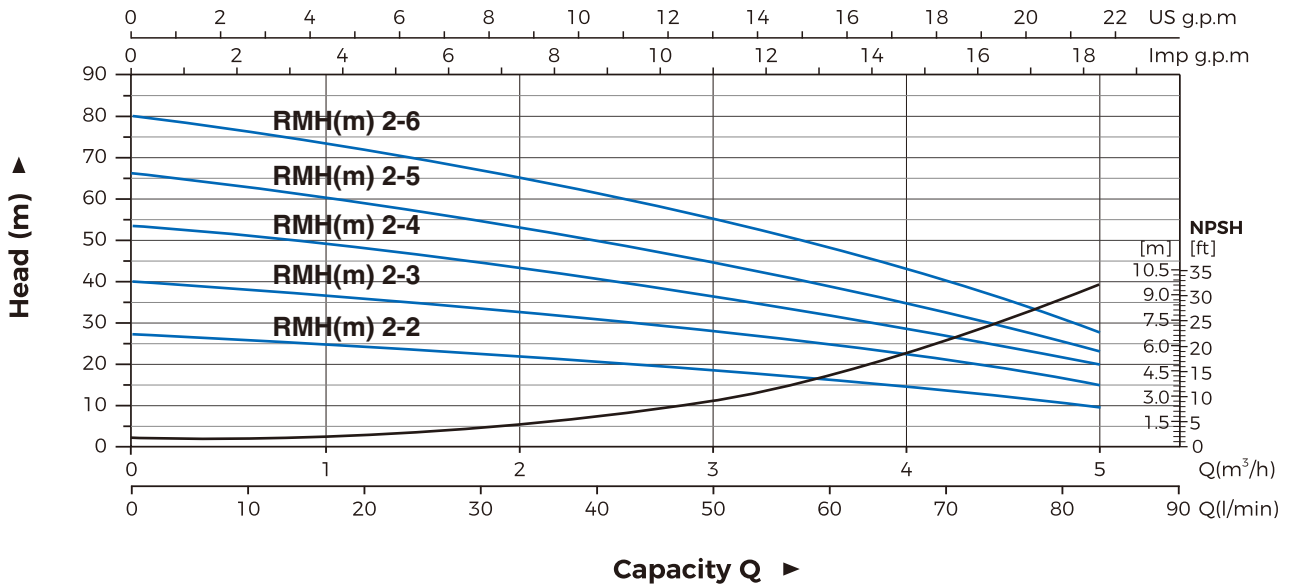

型號	功率		Q(m³/h) Q(l/min)	0	1	1.5	2	2.5	3	3.5	4	4.5	5
	kW	HP		0	16.7	25	33.3	41.7	50	58.3	66.7	75	83
RMH(m) 2-2	0.37	0.5	H (m)	27	24.5	23.5	22	20.5	18.5	17	15	12.5	9.5
RMH(m) 2-3	0.6	0.75		40	37	35	32.5	30.5	28	25.5	22.5	19	14.5
RMH(m) 2-4	0.75	1.0		53	49	46.5	43	40.5	37.5	33.5	28.5	24	19.5
RMH(m) 2-5	1.0	1.5		66	60.5	57	53.5	49.5	45	40	35	30	23.5
RMH(m) 2-6	1.0	1.5		80	74	69.5	65	60	55	49	43	36	27.5

## 尺寸

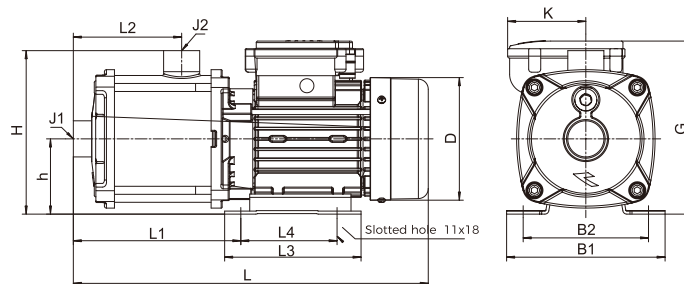

型號	L	L1	L2	L3	L4	h	B1	B2	D	G	K	H	J1/J2
										3~/1~	3~/1~		
RMH(m) 2-2	305	131	72	136	96	75	158	125	122	163/172.5	-/78	163	G1/G1
RMH(m) 2-3	318	131	72	136	96	75	158	125	122	163/172.5	-/78	163	
RMH(m) 2-4	346	149	90	136	96	75	158	125	146.5	172/182.5	-/89	163	
RMH(m) 2-5	364	167	108	136	96	75	158	125	146.5	172/182.5	-/89	163	
RMH(m) 2-6	382	185	126	136	96	75	158	125	146.5	172/182.5	-/89	163	

## 性能曲線

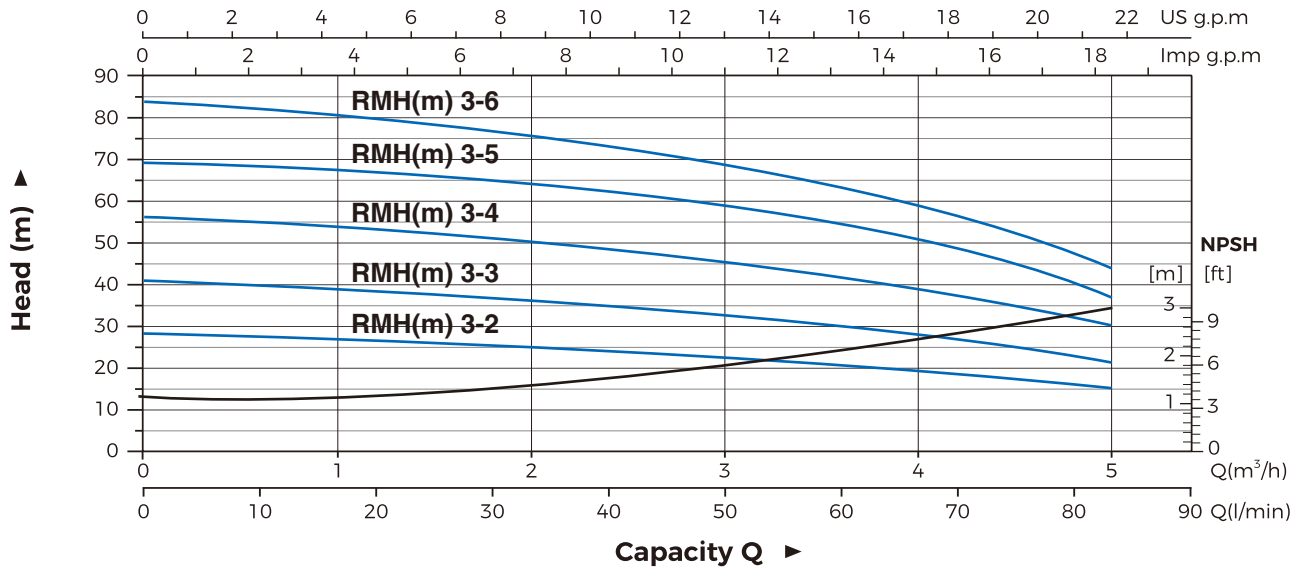

型號	功率		Q(m³/h)	0	1	1.5	2	2.5	3	3.5	4	4.5	5
	kW	HP	Q(l/min)	0	16.7	25	33.3	41.7	50	58.3	66.7	75	83
RMH(m) 3-2	0.37	0.5	H (m)	28	26	25.5	25	24	23	21	20	18	15
RMH(m) 3-3	0.6	0.75		41.5	39	38	37	35.5	33.5	31	28.5	25.5	21
RMH(m) 3-4	1.0	1.5		56	54.5	53	50	48.5	46	41.5	40	35	30
RMH(m) 3-5	1.0	1.5		69.5	66	64	62	59	57	54	50	44	37
RMH(m) 3-6	1.3	1.75		84	80	78	75.5	73	69	65	60.5	53.5	44

## 尺寸

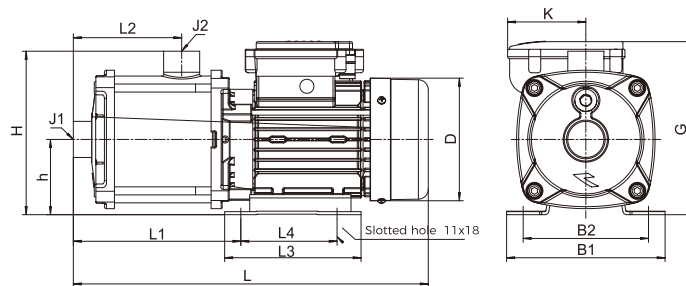

型號	L	L1	L2	L3	L4	h	B1	B2	D	G	K	H	J1/J2
										3~/1~	3~/1~		
RMH(m) 3-2	305	131	72	136	96	75	158	125	122	163/172.5	-/78	163	G1/G1
RMH(m) 3-3	318	131	72	136	96	75	158	125	122	163/172.5	-/78	163	
RMH(m) 3-4	346	149	90	136	96	75	158	125	146.5	172/182.5	-/89	163	
RMH(m) 3-5	364	167	108	136	96	75	158	125	146.5	172/182.5	-/89	163	
RMH(m) 3-6	411	188	126	155	125	90	178	140	167	203/212	-/105.5	178	

## 性能曲線

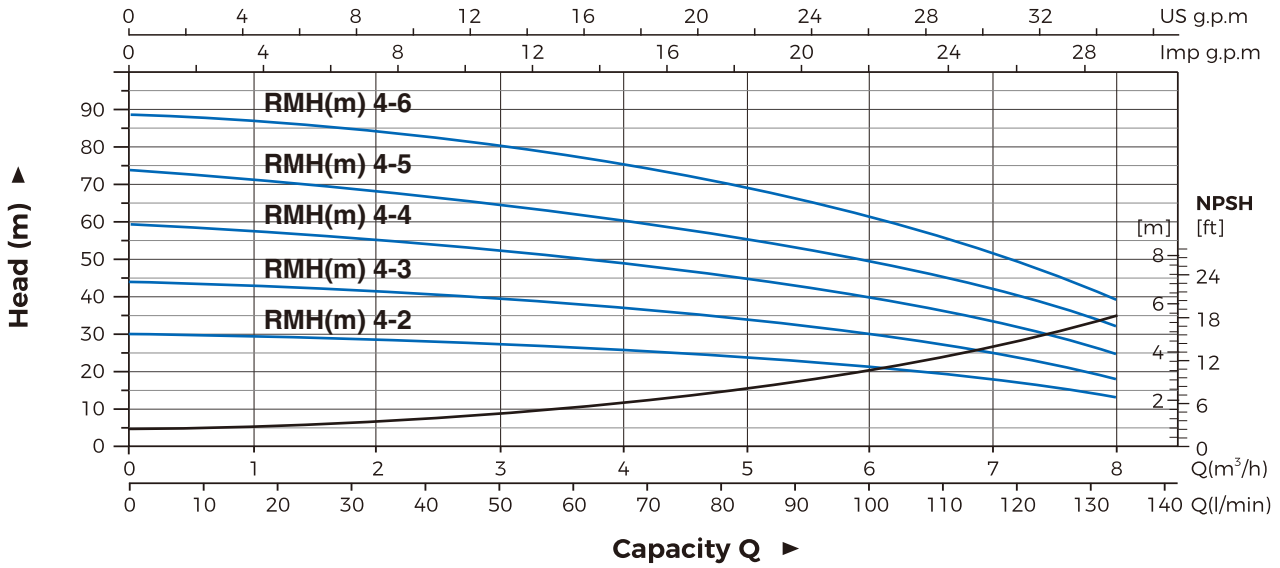

型號	功率		Q(m³/h) Q(l/min)	0	1	2	3	4	5	6	7	8
	kW	HP		0	16.7	33.3	50	67	83	100	117	133.6
RMH(m) 4-2	0.75	1.0	H (m)	30	29	27.5	26.5	24	22.5	19.5	15.5	13
RMH(m) 4-3	1.0	1.5		45	41.5	40.5	38.5	36	32	27	21.5	18
RMH(m) 4-4	1.0	1.5		59	57	54	51.5	48	43.5	37	29	24.5
RMH(m) 4-5	1.5	2.2		74	71.5	68	65	60	56	48	37.5	32
RMH(m) 4-6	1.8	2.4		89	86	82.5	79	74.5	68.5	59	47	39

## 尺寸

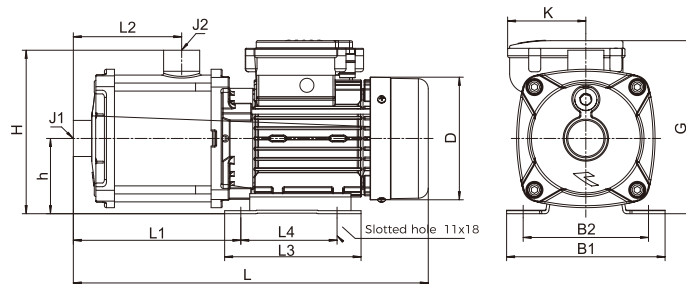

型號	L	L1	L2	L3	L4	h	B1	B2	D	G	K	H	J1/J2
										3~/1~	3~/1~		
RMH(m) 4-2	331	134	75	136	96	75	158	125	122	163/172.5	-/78	163	G1 <sup>1</sup> / <sub>4</sub> /G1
RMH(m) 4-3	331	134	75	136	96	75	158	125	122	163/172.5	-/78	163	
RMH(m) 4-4	349	152	93	136	96	75	158	125	146.5	172/182.5	-/89	163	
RMH(m) 4-5	393	170	111	155	125	90	178	140	167	203/212	-/105.5	178	
RMH(m) 4-6	411	188	129	155	125	90	178	140	167	203/212	-/107	178	

## 性能曲線

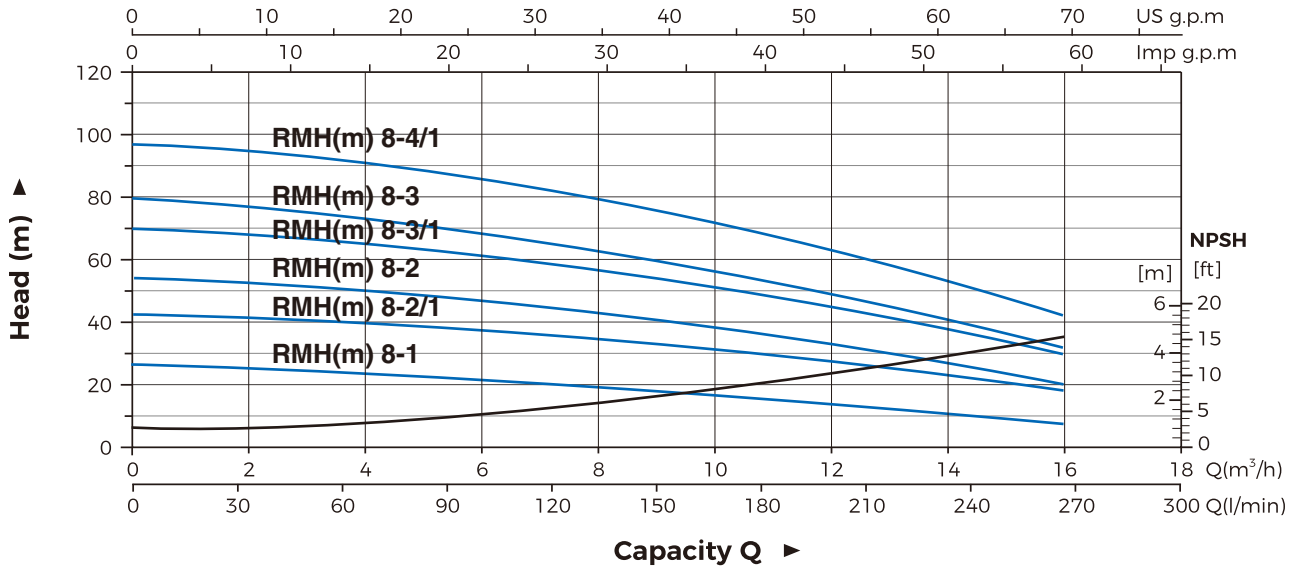

型號	功率		Q(m³/h) Q(l/min)	0	2	4	6	7	8	9	10	12	14	16
	kW	HP		0	33.3	67	100	117	134	150	166	200	233	268
RMH(m) 8-1	0.75	1.0	H (m)	26	25	23.5	21	20	19	17.5	16.5	14	11	7.5
RMH(m) 8-2/1	1.5	2.0		42.5	42	40	37.5	36	35	33	31.5	27.5	23.5	18
RMH(m) 8-2	2.2	3.0		54	52	49	46.5	44.5	42.5	40.5	38.5	33	27	20.5
RMH(m) 8-3/1	2.2	3.0		70	67.5	64	61	58.5	56.5	54	51	44.5	38	29
RMH(m) 8-3	3	4.0		79	76.5	73	68	65.5	62.5	59.5	56.5	49	41	30.5
RMH(m) 8-4/1	3	4.0		97	94	90	85.5	83	79	76	72.5	63.5	53.5	41.5

## 尺寸

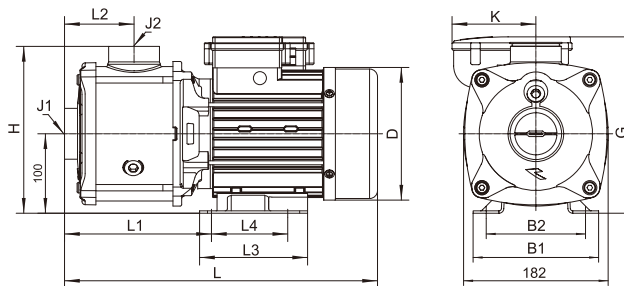

型號	L	L1	L2	L3	L4	B1	B2	D	G	K	H	J1/J2
									3-1~	3-1~		
RMH(m) 8-1	410(378)	200(186)	102.5	136(132)	96	158	125	167(146.5)	213/207.5	-/89	210	G1½/G1½
RMH(m) 8-2/1	410(470)	200	102.5	136(170)	96(140)	158(200)	125(160)	167(175)	213/237	-/107	210	
RMH(m) 8-2	470	200	102.5	170	140	200	160	175	222/237	-/107	210	
RMH(m) 8-3/1	470	200	102.5	170	140	200	160	175	222	-	210	
RMH(m) 8-3	470	200	102.5	170	140	200	160	175	222	-	210	
RMH(m) 8-4/1	500	230	132.5	170	140	200	160	175	222	-	210	

性能曲線

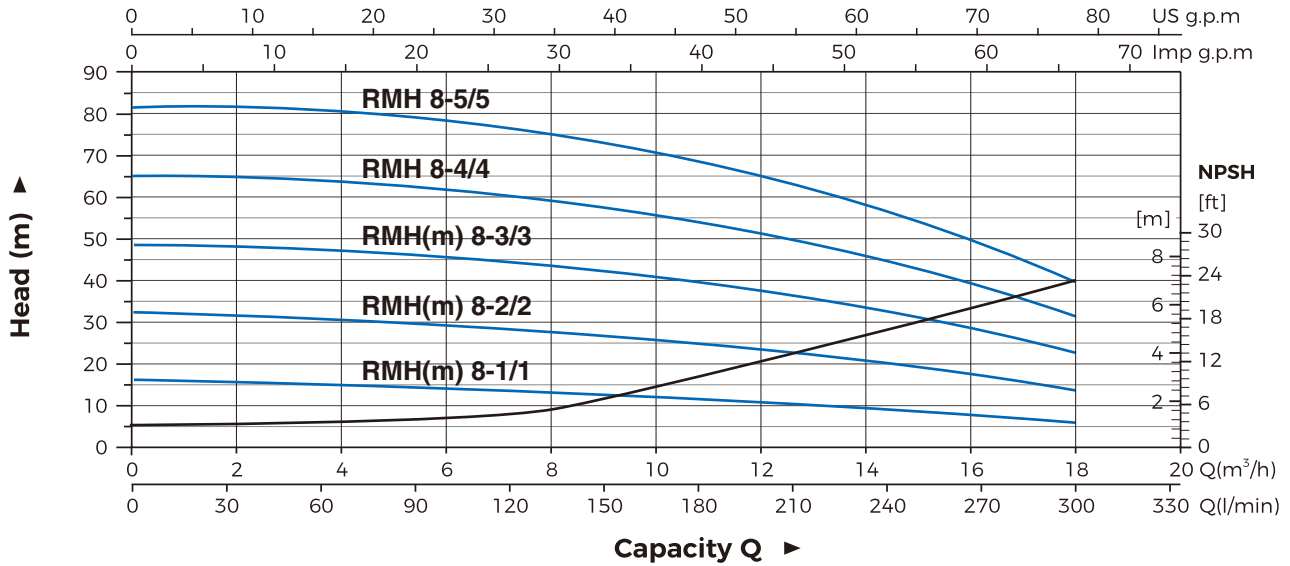

型號	功率		Q(m³/h)	0	2	4	6	7	8	9	10	12	14	16	18
	kW	HP	Q(l/min)	0	33.3	67	100	117	134	150	166	200	233	268	300
RMH(m) 8-1/1	0.75	1.0	H (m)	16	15.5	15	14.5	14	13.5	12.5	12	11	9	7.5	5.5
RMH(m) 8-2/2	1.1	1.5		32	31.5	30.5	29.5	29	28	27.5	26	23.5	20.5	17	13.5
RMH(m) 8-3/3	2.2	3.0		48.5	48	47	46	45	44.5	43	41	38	33	28	22.5
RMH 8-4/4	2.2	3.0		65	64.5	63	62	61	60	58	56.5	51	45.5	39	31
RMH 8-5/5	3	4.0		81.5	81	79	78	77	75.5	73.5	71	65.5	57.5	49	39.5

尺寸

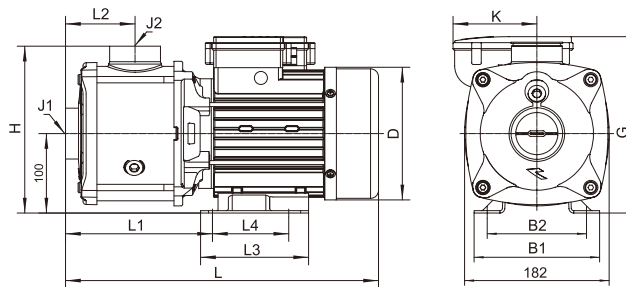

型號	L	L1	L2	L3	L4	B1	B2	D	G	K	H	J1/J2
									3~/1~	3~/1~		
RMH(m) 8-1/1	378	186	102.5	132	96	158	125	146.5	197/207.5	-/89	210	G1 1/2/G1 1/2
RMH(m) 8-2/2	410	200	102.5	136	96	158	125	167	213/222	-/105.5	210	
RMH(m) 8-3/3	410(470)	200	102.5	136(170)	96(140)	158(200)	125(160)	167(175)	213/237	-/107	210	
RMH 8-4/4	500	230	132.5	170	140	200	160	175	222	-	210	
RMH 8-5/5	530	260	162.5	170	140	200	160	175	222	-	210	

性能曲線

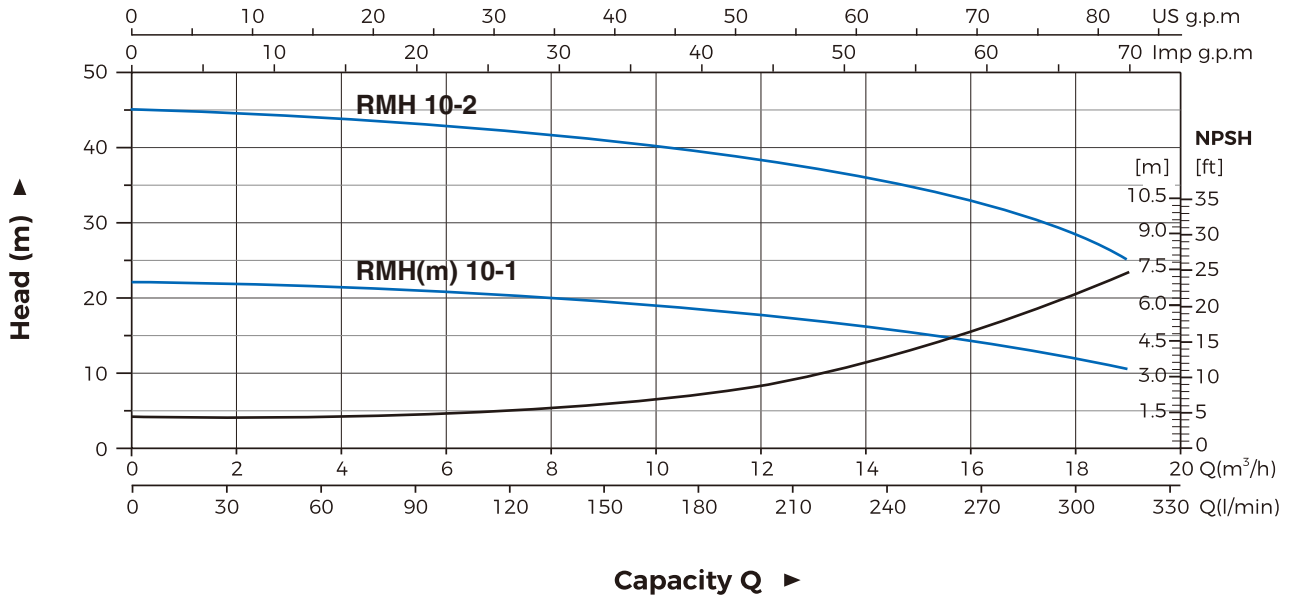

型號	功率		Q(m³/h) Q(l/min)	0	4	6	8	10	12	14	16	18	19
	kW	HP		0	67	100	134	166	200	233	268	300	317
RMH(m) 10-1	1.1	1.5	H (m)	22	21.5	21	20.2	19	17.5	16	14.2	12	10.5
RMH 10-2	2.2	3.0		45	44	43	41.5	40	38	36	33	28.5	25

尺寸

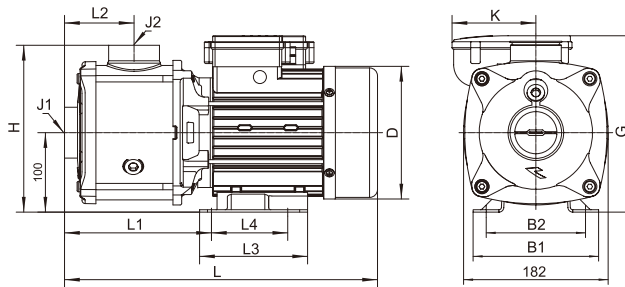

型號	L	L1	L2	L3	L4	B1	B2	D	G	K	H	J1/J2
									3-1~	3-1~		
RMH(m) 10-1	410	200	102.5	136	96	158	125	167	213/222	-/105.5	210	G1½/G1½
RMH 10-2	470	200	102.5	170	140	200	160	175	222	-	210	

性能曲線

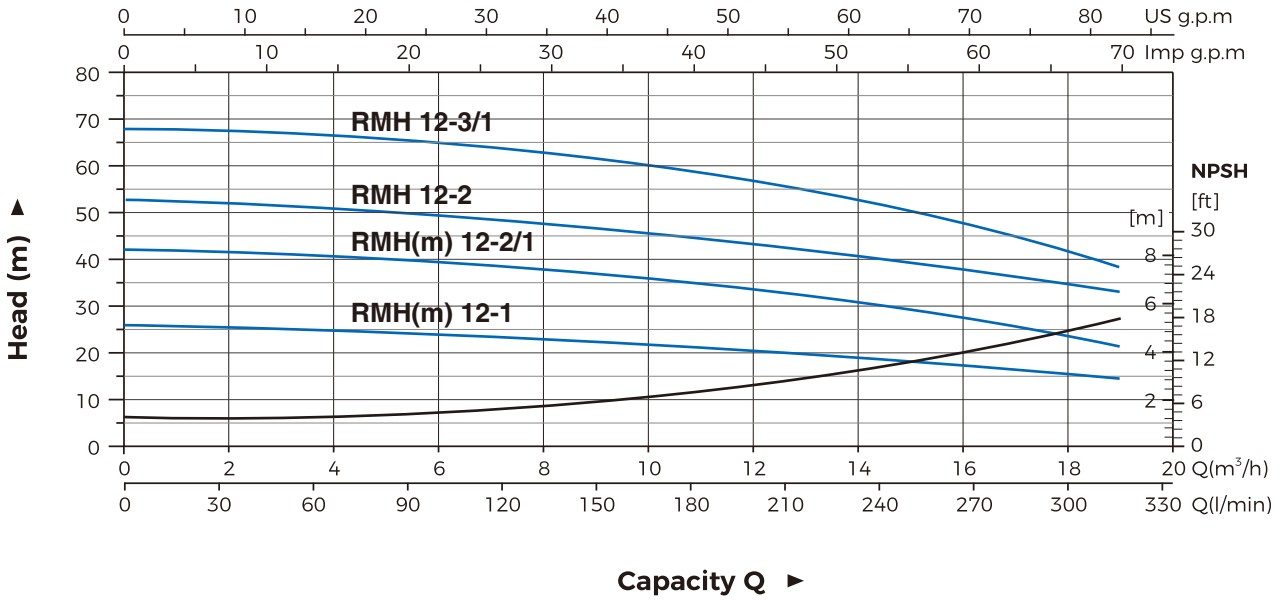

型號	功率		Q(m³/h) Q(l/min)	0	4	6	8	10	12	14	16	18	19
	kW	HP		0	67	100	134	166	200	233	268	300	317
RMH(m) 12-1	1.5	2.0	H (m)	26	24.5	24	23	21.5	20	19	17	15.5	14.5
RMH(m) 12-2/1	1.8	2.5		42	40	39	38	36	34	31	27.5	23.5	21
RMH 12-2	3.0	4.0		52.5	50.5	49.5	48	46	44	41	38	35	33
RMH 12-3/1	3.0	4.0		67.5	66	64.5	62.5	60	57	53	48	42	39

尺寸

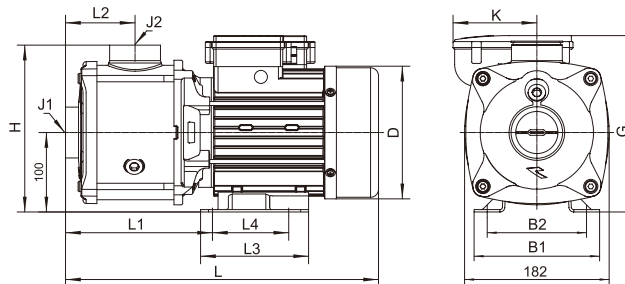

型號	L	L1	L2	L3	L4	B1	B2	D	G	K	H	J1/J2
									3~/1~	3~/1~		
RMH(m) 12-1	410(470)	200	102.5	136(170)	96(140)	158(200)	125(160)	167(175)	213/237	-/107	210	G1½/G1½
RMH(m) 12-2/1	410(470)	200	102.5	136(170)	96(140)	158(200)	125(160)	167(175)	213/237	-/107	210	
RMH 12-2	470	200	102.5	170	140	200	160	175	222	-	210	
RMH 12-3/1	470	200	102.5	170	140	200	160	75	222	-	210	

## 性能曲線

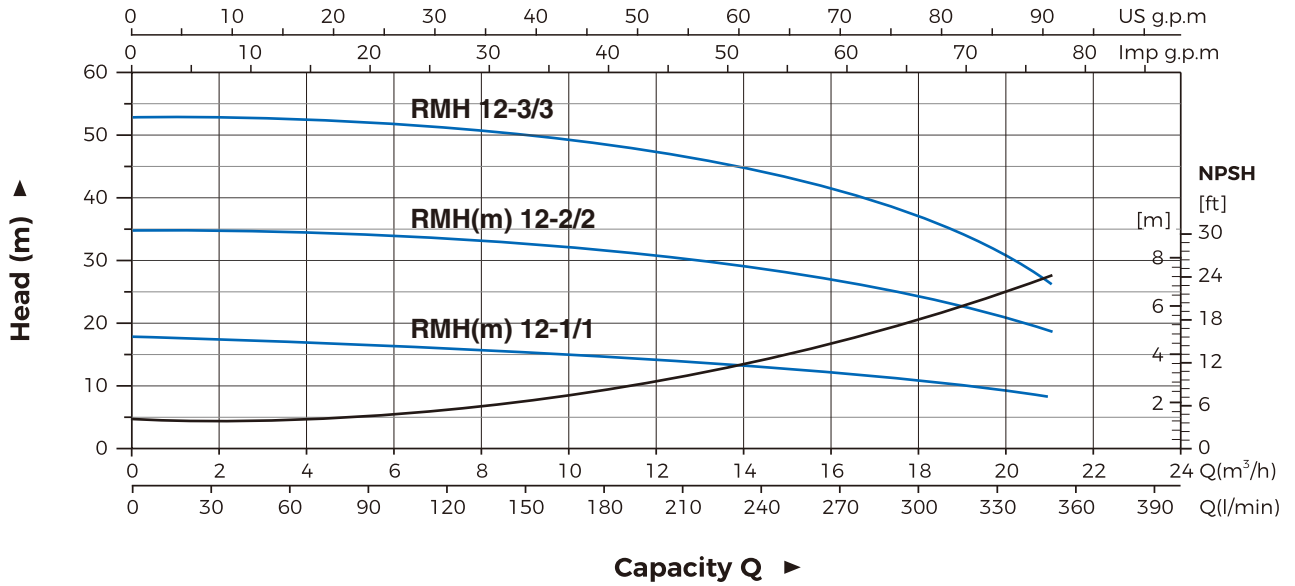

型號	功率		Q(m³/h) Q(l/min)	0	4	6	8	10	12	14	16	18	20	21
	kW	HP		0	67	100	134	166	200	233	268	300	333	350
RMH(m) 12-1/1	1.1	1.5	H (m)	17.5	16.5	16	15.5	15	14	13	12	11	9	8
RMH(m) 12-2/2	1.8	2.5		34.5	34	33.5	33	32	31	29	27	24.5	20.5	18.5
RMH 12-3/3	3.0	4.0		52.5	52	51	50	49	47.5	45	42	38	31	26

## 尺寸

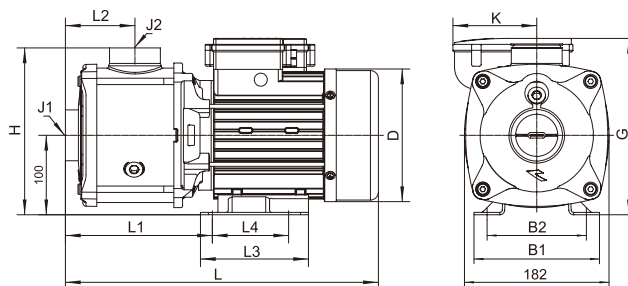

型號	L	L1	L2	L3	L4	B1	B2	D	G	K	H	J1/J2
									3~/1~	3~/1~		
RMH(m) 12-1/1	410(378)	200(186)	102.5	136(132)	96	158	125	167(146.5)	213/210	-/89	210	G1 1/2/G1 1/2
RMH(m) 12-2/2	410(470)	200	102.5	136(170)	96(140)	158(200)	125(160)	167(175)	213/237	-/107	210	
RMH 12-3/3	470	200	102.5	170	140	200	160	175	222/-	-	210	

性能曲線

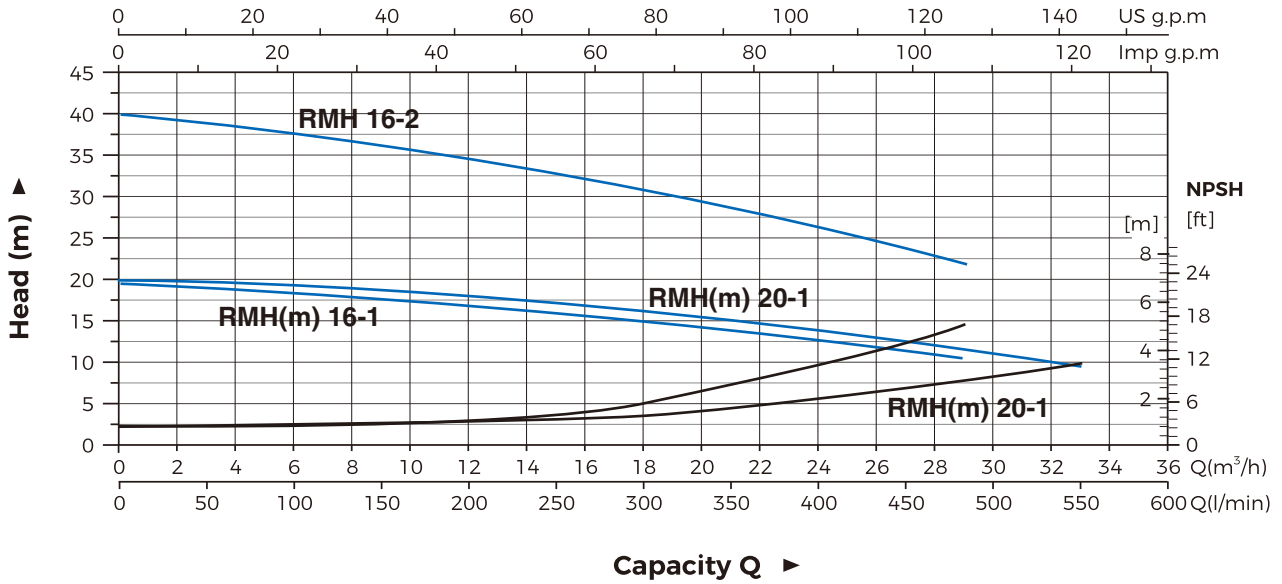

型號	功率		Q(m³/h) Q(l/min)	0	6	10	14	16	18	20	22	24	26	29	32	33
	kW	HP		0	50	166	233	268	300	333	367	400	433	483	533	550
RMH(m) 16-1	1.5	2.0	H (m)	19.5	18	17	16.2	15.5	14.9	14	13.2	12.5	11.5	10	-	-
RMH 16-2	3.0	4.0		40	37	35.5	33	32.5	31	29.5	27.6	26.5	24.8	21	-	-
RMH(m) 20-1	1.8	2.5		20	19	18	17.1	16.5	16	15.5	14.9	14.2	13.4	12	10	9

尺寸

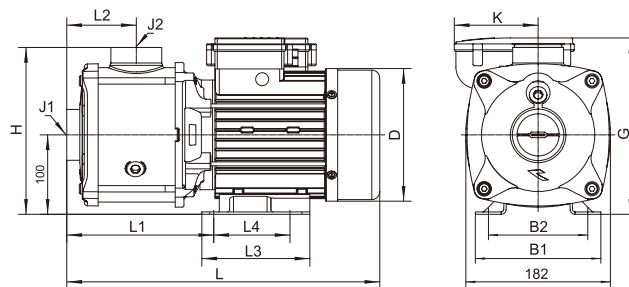

型號	L	L1	L2	L3	L4	B1	B2	D	G	K	H	J1/J2
									3~/1~	3~/1~		
RMH(m) 16-1	394(455)	185	87.5	136(170)	96(140)	158(200)	125(160)	167(175)	213/237	-/107	211	G2/G2
RMH 16-2	454	185	87.5	170	140	200	160	175	222/-	-	211	
RMH(m) 20-1	392(455)	185	87.5	136(170)	96(140)	158(200)	125(160)	167	213/237	-/107	211	