

The Volt is the New Chip

Whoever controls GOES steel and Direct Current (DC) controls the hegemony of AI computing infrastructure.

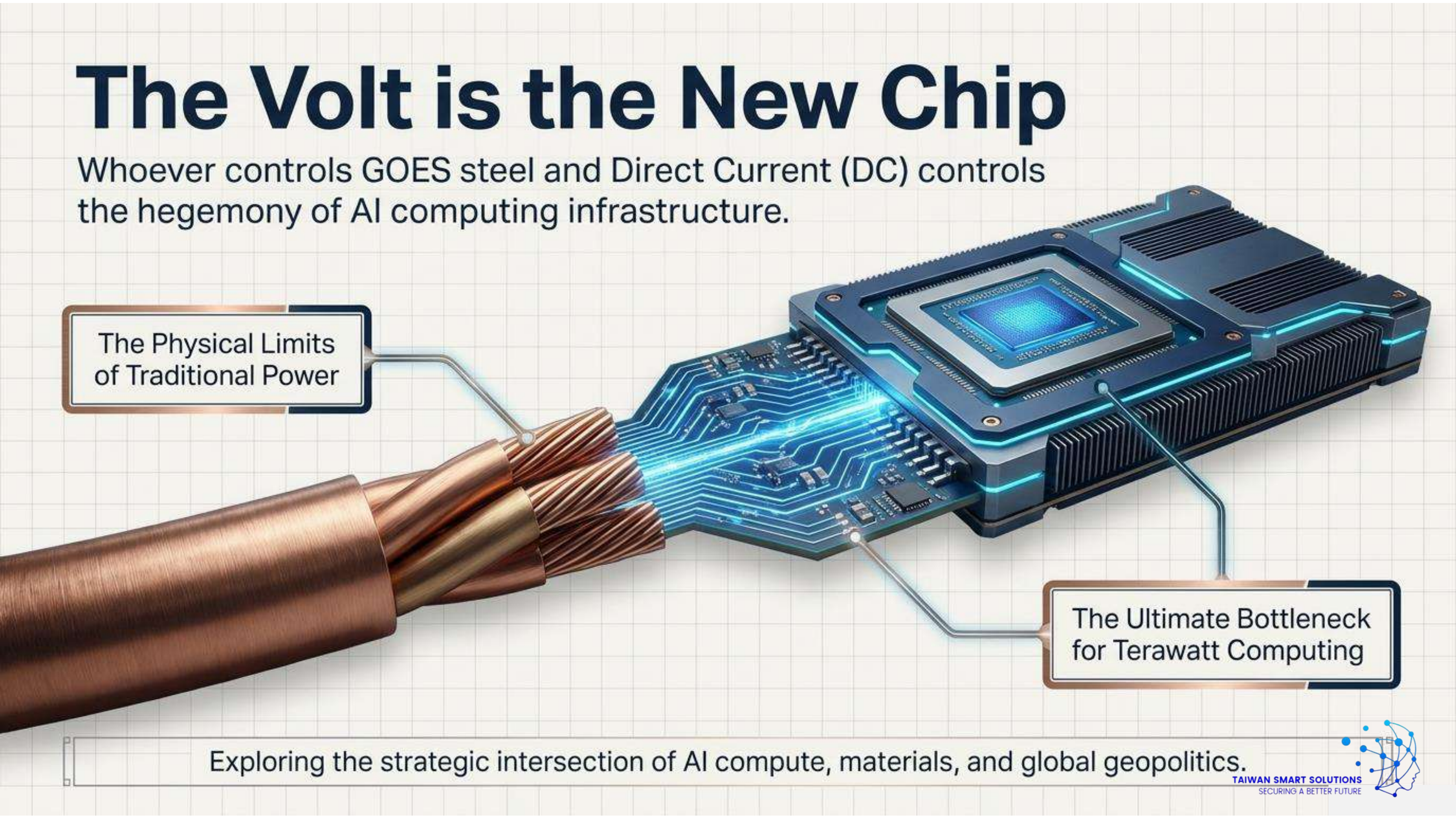

The Physical Limits
of Traditional Power

The Ultimate Bottleneck
for Terawatt Computing

Exploring the strategic intersection of AI compute, materials, and global geopolitics.

The 2.5-Year Bottleneck: A Market Awakening



4.33 NTD

(Record Q1 2026 EPS)

A Taiwanese wire and cable manufacturer successfully entered the US Arizona semiconductor supply chain, marking the pivot of Taiwan's heavy electrical sector into the core global AI compute race.



30% Deficit

The current global shortfall in power equipment supply relative to exploding AI data center demand.



**2.5-Year
Lead Time**

The average wait time required to procure large-scale transformers globally.

The Collapse of a Century-Old Law: “Diversity” Meets “Physical Pulse”

The Old World (Legacy Grid)

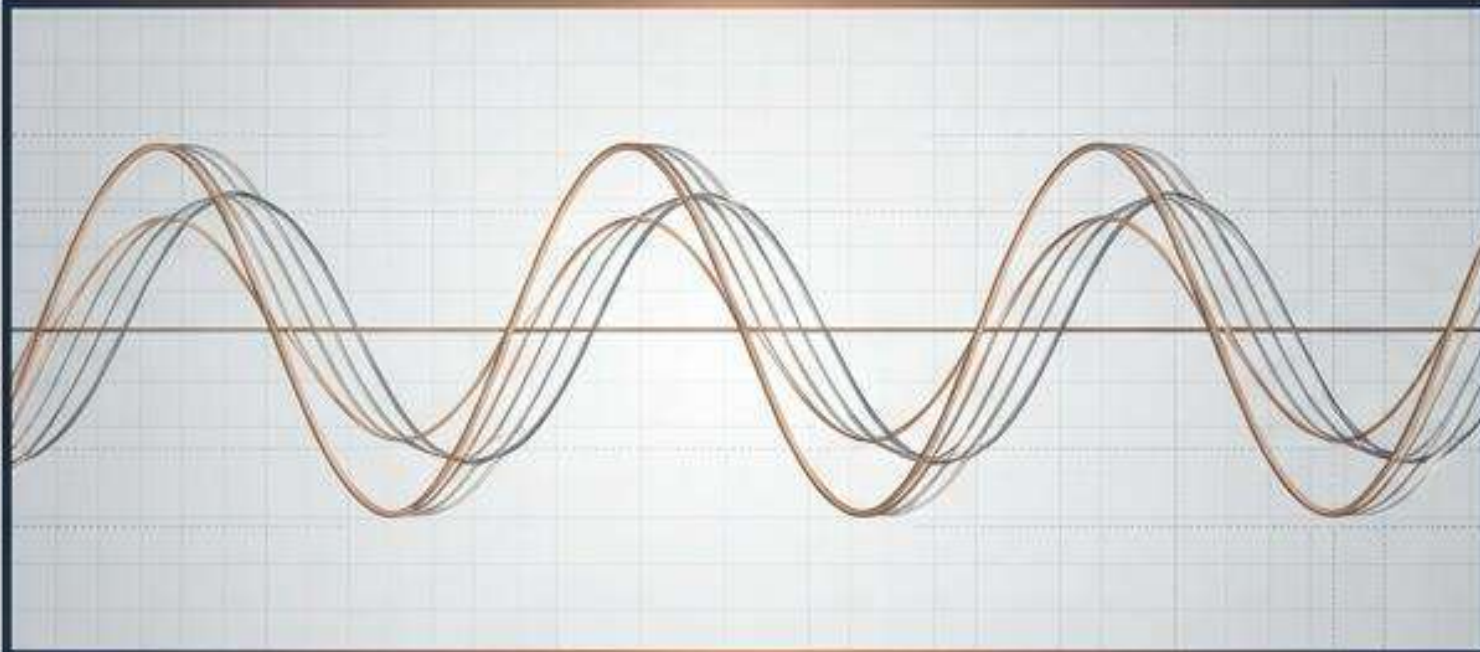

- Load Diversity
- Millions of users drawing power asynchronously and randomly.

The New World (AI Compute)

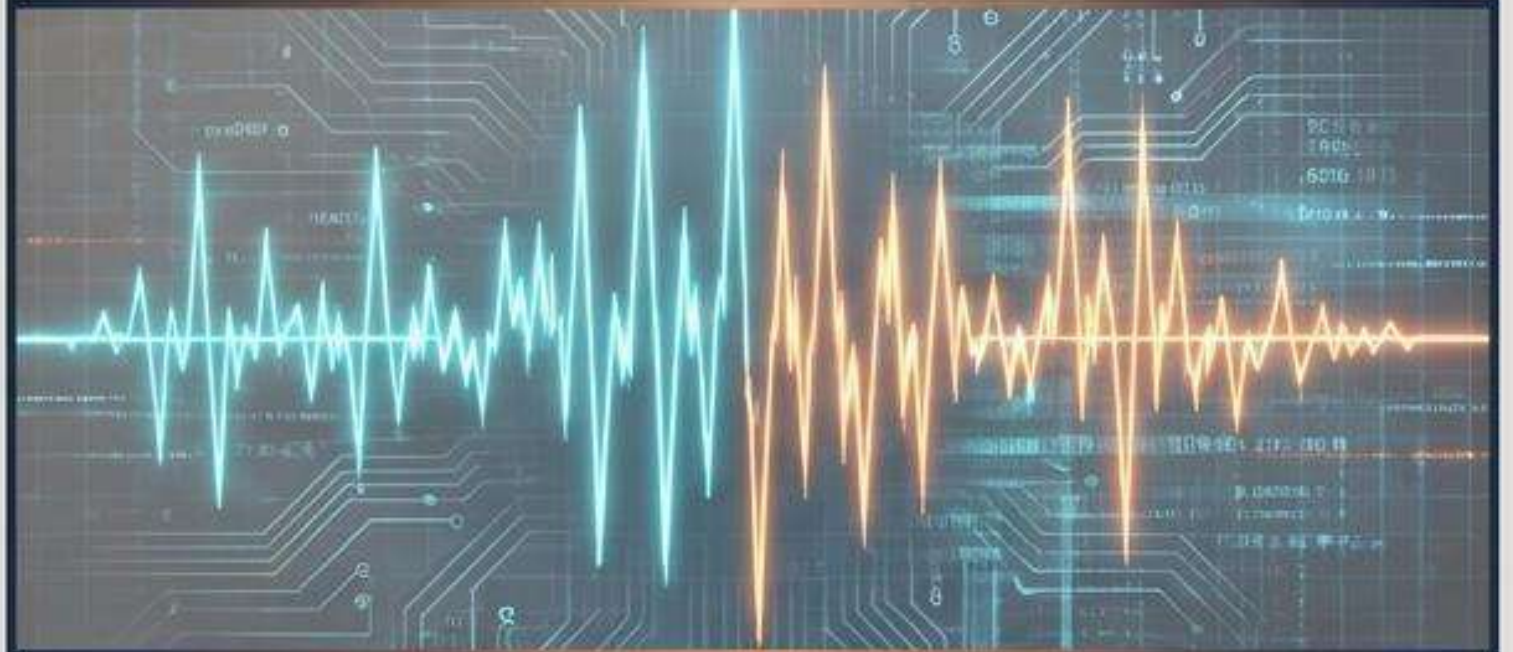

- Synchronous Pulse
- Tens of thousands of GPUs computing and saving data simultaneously, creating brutal power spikes.

“AI loads act like steel mills—extreme speed, massive scale. In July 2024, a Virginia transmission fault caused 1.5GW of data center load to drop in seconds, becoming a prime threat to grid frequency stability.” — Texas RE (Reliability Services)

Two Worlds Colliding: Software-Defined vs. Physics-Defined

Worldview Collision

Data Center Logic

RAID Logic
(Assumes hardware will fail; built for redundancy)

Cycle:
18–24 month hardware iterations

Philosophy:
Speed > Stability
(Failure is just the cost of learning)



Utility Logic

Mainframe Logic
(Hardware must be absolutely reliable)

Cycle:
10+ year infrastructure planning

Philosophy:
Stability > Speed
(Zero downtime required; multi-year waitlists)

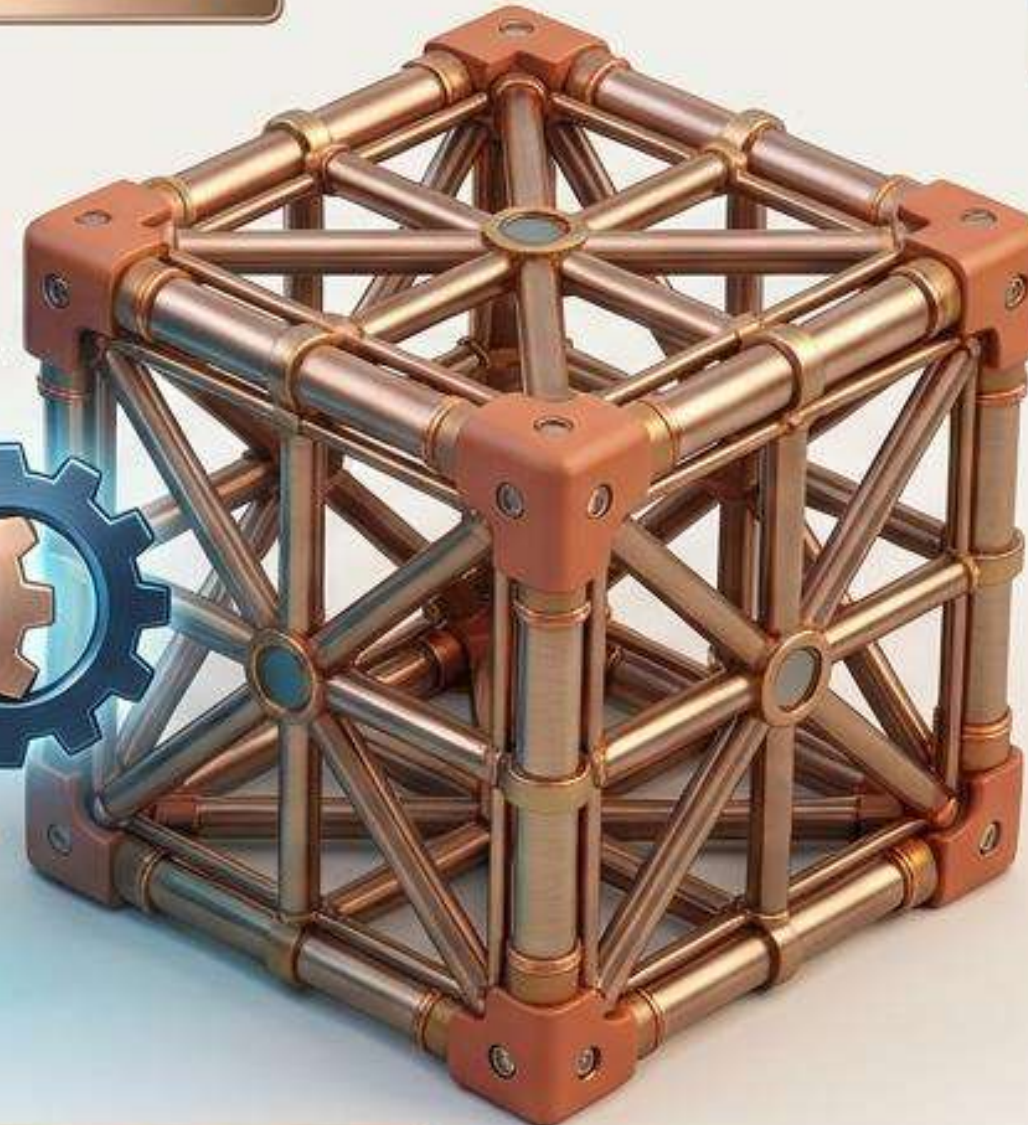

The Center Synthesis (Co-Design)

Moving from a "Giant Lightbulb" passive consumer model to "Internet Peering" smart-grid integration.

The Ignored Strategic Material: Transformer Heart 'GOES'

The unnoticed **material crisis**, now creating a unique pricing power window.

Perfect Storm Funnel



Architecture Revolution: The AC vs. HVDC Efficiency Duel

Energy Waterfall Chart

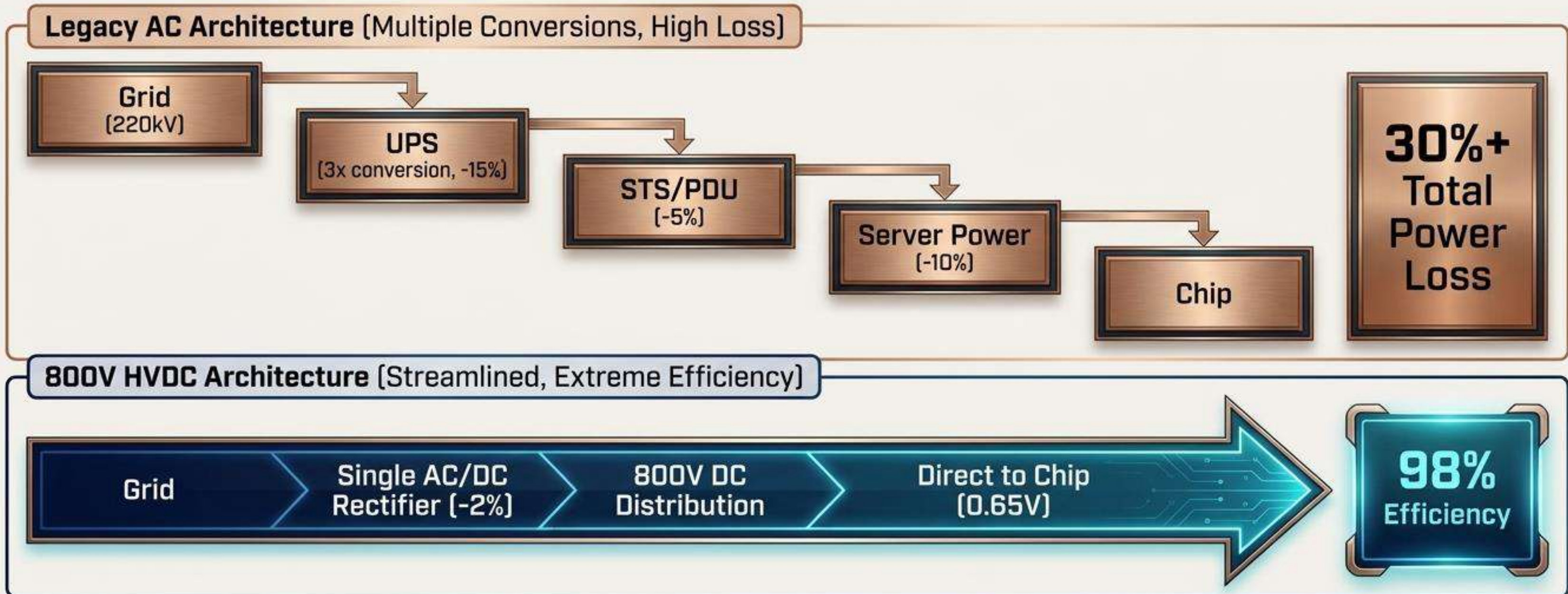

Strategic Takeaway: Every 1% of power saved equals millions in annual operational savings. HVDC is rapidly evolving from a long-distance grid tool to the internal standard for AI Data Centers.







The HVDC Explosive Growth Trajectory

Global AI Data Center HVDC Market Size (2025–2035)

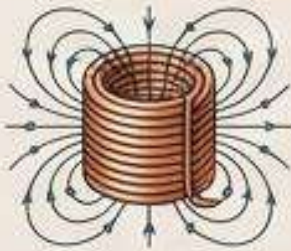
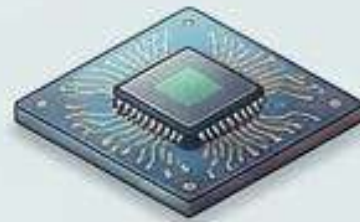

NVIDIA's Next Step: Solid-State Transformers (SST)

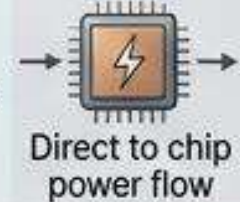
Named explicitly in the "800VDC Architecture" whitepaper as the revolutionary replacement for legacy transformers.

	Traditional Iron-Core	SST Solid-State
Core Principle	50/60 Hz Electromagnetic Induction 	Power Semiconductor High-Frequency Switching (10k-200kHz) 
Physical Form	Bulky (1-2 tons, fixed) 	60-90% smaller (Modular design) 
Efficiency	88-92% (Eliminates complex AC/DC conversion chains) 	98.3%  →  Direct to chip power flow
Strategic Role	Passive (Blindly accepts grid state) 	Software-Defined Smart Node (Proactively regulates the grid) 

Bottom Insight: SSTs turn data centers from "dumb consumers" into active "smart nodes."
Whoever controls the SST supply chain controls the next generation.



The 'Fence Effect': Taiwan's Geopolitical Monopoly

Geopolitical and Technical Convergence

The Situation (The Wall):

Global geopolitical barriers have effectively excluded the world's largest power equipment manufacturing base (China) from core US and European markets, fundamentally restructuring global supply chains.

Taiwan's Triple Advantage (The Arrows):



1. Strategic Partner Upgrade:

Transitioning from "alternative supplier" to "indispensable partner" for the West.



2. Local Ecosystem: A fully formed HVDC cluster (Power, Backup, Cooling, Racks) already exists on the island.



3. Fast Delivery: The unique capability to rapidly deliver MW-scale HVDC solutions, breaking the 2.5-year bottleneck.

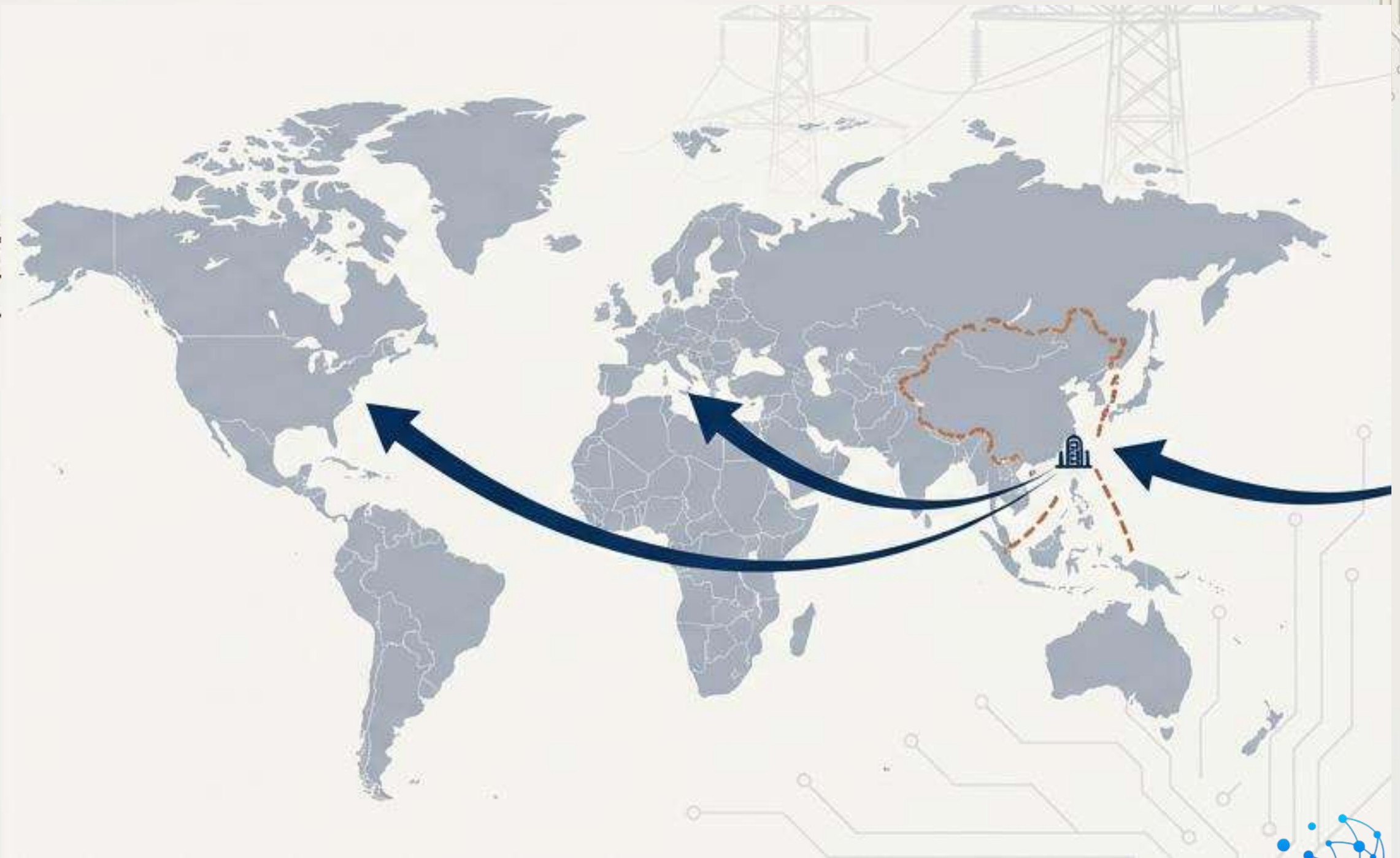

The Heavy Electrical Four: Taiwan's Strategic Arsenal

Strategic Deployment Matrix

Fortune Electric (1519) - The AIDC Leader

Position Block

Successfully deployed in the Texas AI Data Center "Stargate" project.

Metric Block

AI-related revenue expected to break 10% for the first time in 2026.

Shilin Electric (1503) - Comprehensive Layout

Position Block

Aggressively developing mainstream 230kV grade products for the US.

Metric Block

Order visibility extends all the way to 2030.

Chung-Hsin Electric (1513) - Semiconductor Integration

Position Block

Domestic Gas Insulated Switchgear (GIS) leader; certified TSMC supplier.

Metric Block

Projected to contribute 1.8 billion NTD in revenue by 2026-27.

Allis Electric (1514) - Turnkey Integrator

Position Block

Binding with semiconductor fabs; pursuing turnkey data center contracts in Central/South America.

Metric Block

Delivery times beat European/American OEMs by half a year.



The TSSA Ecosystem: Engineering Supply Chain Resilience

Accelerator A: Digital Twins (The Material Defense Line)

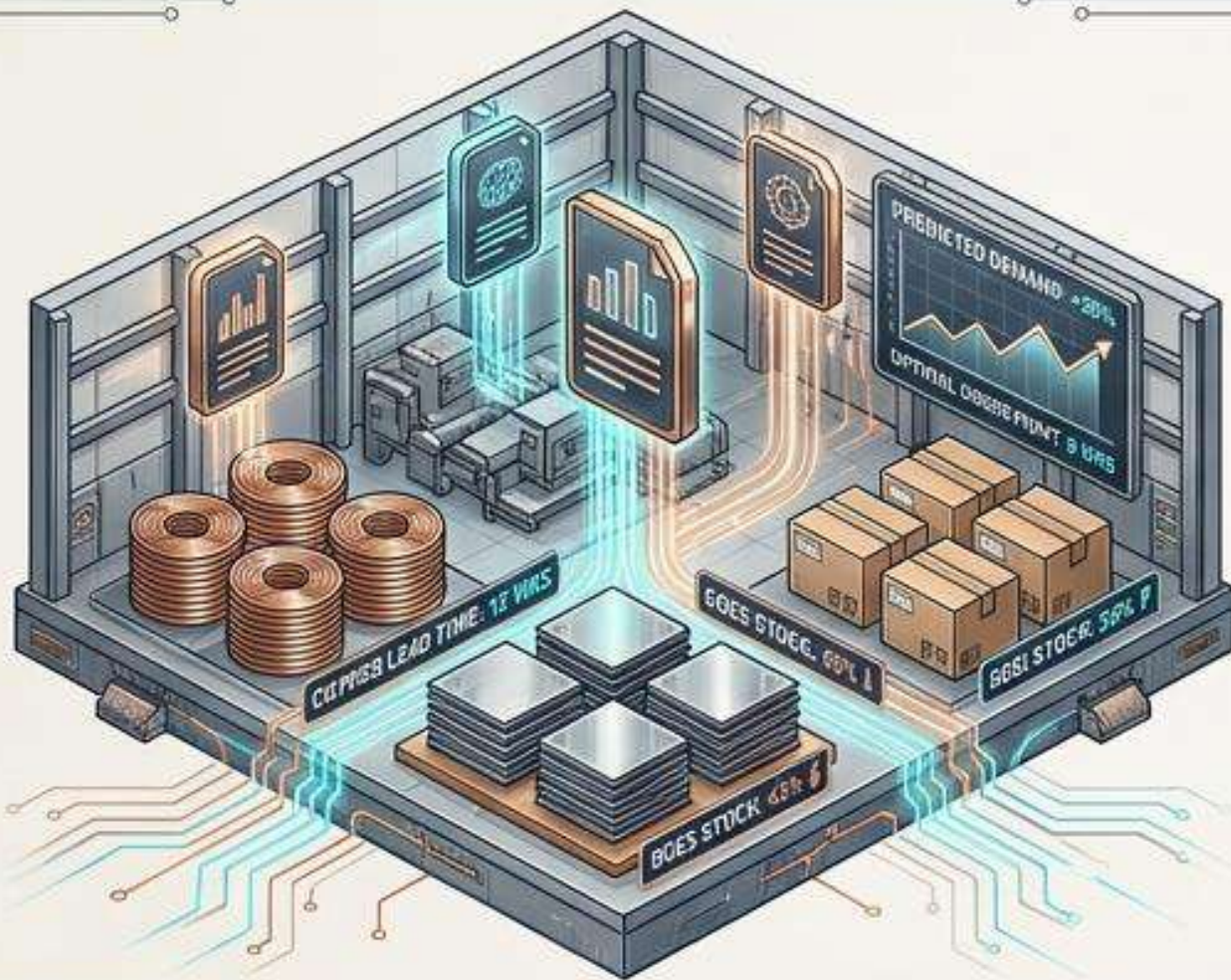

- **Pain Point:** High supply risk for GOES steel and copper.
- **Solution:** Real-time digital modeling of raw material inventory (e.g., predicting 12-week copper lead times against a +20% demand spike).
- **Effect:** Predictive procurement optimizes production, establishing the first line of defense for gross margins.

Accelerator B: Global Networking (The Second Beachhead)

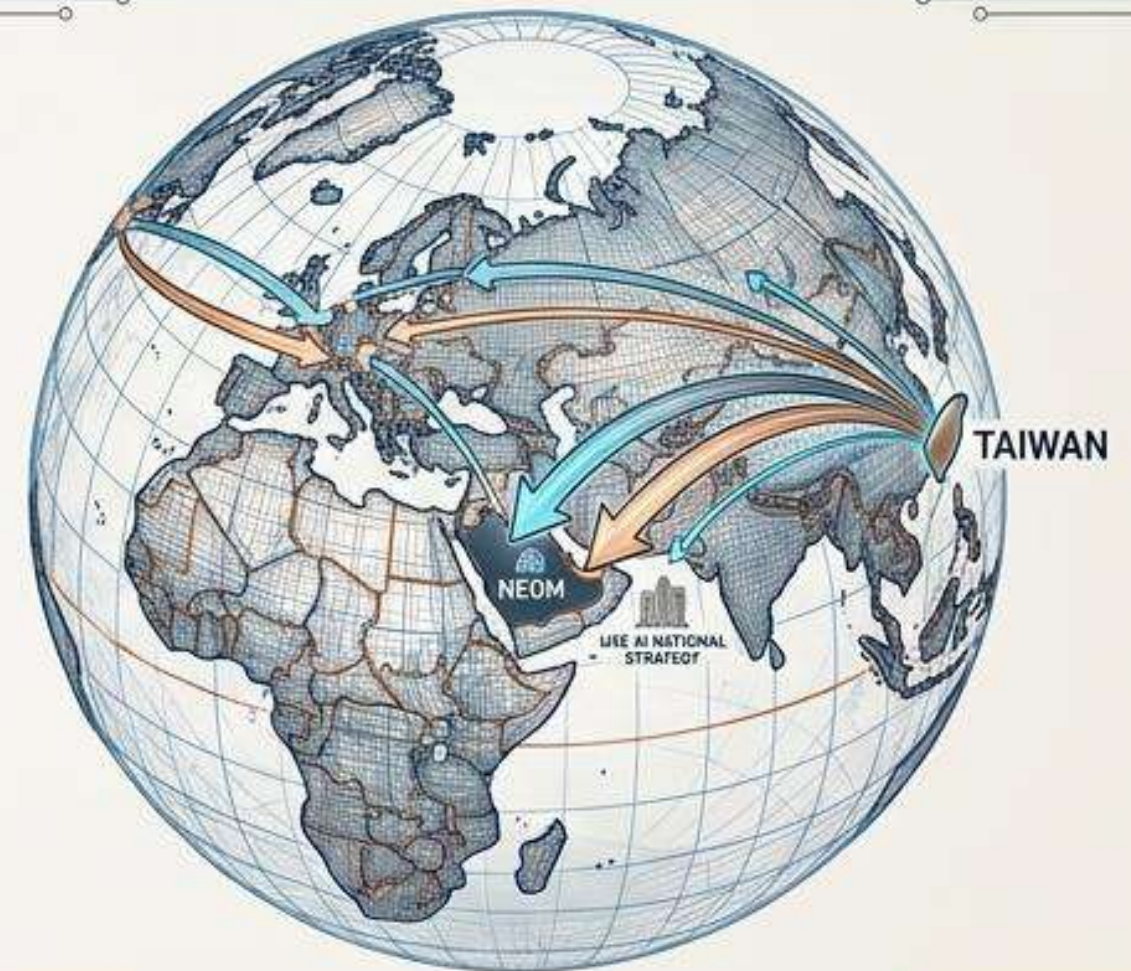

- **Pain Point:** Over-concentration in the US market.
- **Solution:** Leveraging TSSA networks across North America, Europe, and the Middle East.
- **Effect:** Targeting high-value HVDC demand in sovereign AI strategies like Saudi Arabia's NEOM and the UAE.

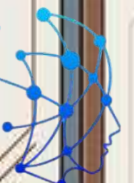

Crossing the Wall: From Hardware Vendors to Energy-as-a-Service



Accelerator C: ESG Compliance Integration

The Wall: Strict carbon border mechanisms (EU CBAM, US FCC) act as soft barriers to entry.

The Bridge: Implementing TSSA's standardized carbon management and sustainability reporting to effortlessly clear compliance hurdles.

Accelerator D: Agentic AI Application

The Wall: Pure hardware sales lack long-tail value and competitive moats.

The Bridge: Deploying Agentic AI and sensor networks to transform vendors into EaaS providers, offering predictive maintenance and power optimization.

The Endgame Insight: The AI Infrastructure Competitiveness Pyramid

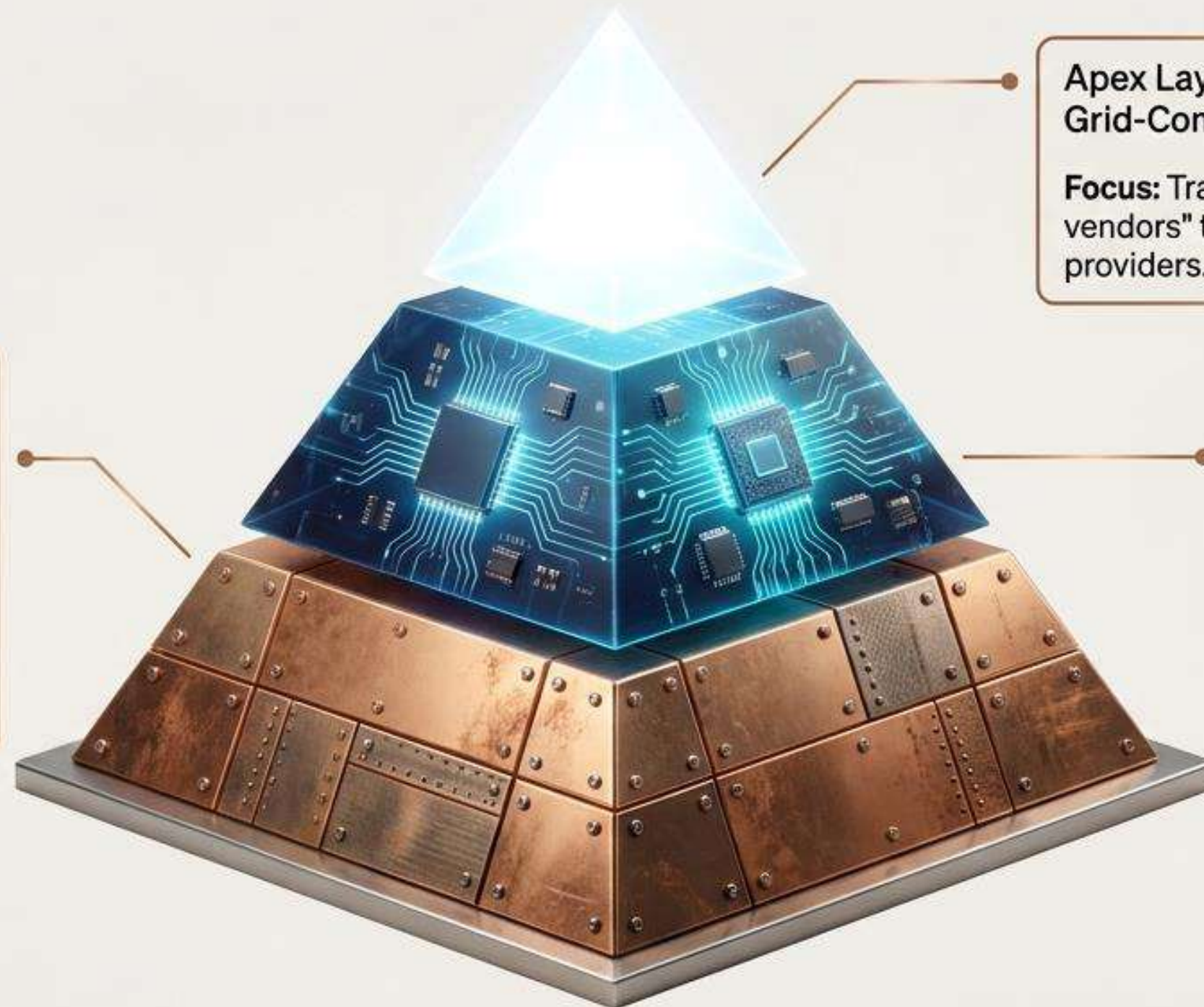

Base Layer (Depth / The Moat): Supply Chain & Materials

Focus: GOES Steel & Long-term material contracts.

Meaning: Mastery of physical materials dictates your current defensive power, pricing authority, and sheer ability to ship.

Apex Layer (Height / Industry Position): Grid-Compute Co-Design

Focus: Transforming from passive "equipment vendors" to active "grid nodes" and EaaS providers.

Middle Layer (Width / The Bo): Technological Architecture

Focus: 800V HVDC & Solid-State Transformers (SST).

Meaning: Tomorrow's expansion capability. Determines if you can capture the "98% extreme efficiency" next-generation orders.



The Sovereign Defense Line



The most underestimated scarce resource in the AI era is not the chip, but the Volt. **Power** is no longer just energy; **it is a line of sovereign defense.**

Taiwan stands at a historic crossroads: The geopolitical umbrella has provided the time. Technological accumulation has provided the starting point. The TSSA ecosystem provides the accelerator.

The only question remaining—who can translate this geopolitical advantage into a technological monopoly before the window closes?



**James Chiao, Founder of International Transformation Consultants,
Founding Chairman of Taiwan Smart Solutions Association**

-  - Consultant to the World Bank & EBRD.
-  - Host of 70+ global strategic transformation seminars.
-  - TSSA encompasses 365+ member enterprises across 27 smart solution domains.

#AI Power Collision	#GOES Steel	#HVDC
#Solid-State Transformers (SST)	#Grid Elasticity	#Heavy Electrical Four
#Geopolitics	#Digital Twin	#EaaS

For deep-dive collaboration or speaking engagements: info@smartcitiesgroup.net